

Product Code: SYS -ROCOMP

WARNING: For correct operation & installation, it is essential to observe these instructions

COMPACT REVERSE OSMOSIS



Note: The whole house water filtration system works as the pre-filtration stages that a regular reverse osmosis needs.

Product Code: SYS -ROCOMP

CONTENTS

compact reverse osmosis	1
Installation and Operation Manual	3
AquaCo Customer Service	3
Guidelines and Warnings.....	Error! Bookmark not defined.
Operation	3
Installation.....	4
Before Installation.....	Error! Bookmark not defined.
COMPACT REVERSE OSMOSIS Typical Installation	5
Installation Procedure	6
Faucet Installation Procedure.....	8
Faucet Installation Procedure	8
Guide to use Push-In Tube Connectors.....	9
Use Guidelines	9
Cartridge Replacement Guide.....	10
Membrane Service/Maintenance	11
Alkalisising Inline Service / Maintenance.....	11
Replacement Parts and Components.....	12
Performance Data Sheet	13
Notes	14
Warranty	14
Warranty/Australia.....	14

Product Code: SYS -ROCOMP

INSTALLATION AND OPERATION MANUAL

AQUACO CUSTOMER SERVICE

Thank you for purchasing an AquaCo Compact Reverse Osmosis System. Your system is a proven performer manufactured from only quality materials and components and will give years of 'spring fresh' water free of impurities if maintained properly.

The AquaCo filter systems cartridges need replacing regularly to maintain optimum performance. This is a simple procedure when following instructions. For cartridge replacements contact your nearest AquaCo stockiest

The system is designed for metropolitan supply water but can be used in other situations. For other types of water supply please contact your local AquaCo stockist or call our AquaCo Customer Service Help line prior to installing the tap.

Customer Service Helpline 08 6156 0220 (Australia).

MINIMUM AND MAXIMUM OPERATING CONDITIONS

Condition	Minimum	Maximum
Inlet Pressure	300 kPa	875* kPa
Inlet Temperature	0°C	30°C
Inlet TDS	50 mg/L	2,000 mg/L
Inlet Hardness	0 mg/L (0 grain)	171 mg/L (10 grain)
Inlet Silt Density Index	0	5 NTU

Note: Where line pressure exceeds 500 kPa, an approved pressure limiting device must be installed to comply with Australian & New Zealand Plumbing Standards.

OPERATION

The AquaCo reverse osmosis systems is designed to run economically for many years, dependent on the initial installation and periodical maintenance.

Flush systems for 10 minutes after any period of non-use more than 2 days. For a period of non-use of 2 weeks or more, it may be necessary to replace cartridges.

This product must be installed in accordance with local plumbing regulations by a licensed plumber.

Installation Note: A water filter system/tap, like any product, has a limited life and may eventually fail. Also, sometimes failure happens early due to unforeseen circumstances. To avoid possible property damage, this product should be regularly examined for leakage and/or deterioration and replaced when necessary. A drain pan, plumbed to an appropriate drain or outfitted with a leak detector, should be used in those applications where any leakage could cause property damage, and/or the water supply should be turned off if no one is home/present.

INSTALLATION MUST BE COMPLETED BY A LICENCED PLUMBER. FAULTY OPERATION DUE TO UNQUALIFIED PERSONS WILL RESULT IN VOIDED WARRANTY COVERAGE.

Product Code: SYS -ROCOMP

Note: Chlorine (free chlorine) tolerance is 1ppm - high chlorine levels permanently damage the reverse osmosis membrane & is not covered under warranty. The maintenance of the pre-filtration system is always recommended to protect the performance of the reverse osmosis membrane.

INSTALLATION

This system comes complete with an installation kit enabling it to be connected to 15mm (½") copper pipe (cold supply only - hot water should be filtered prior to heating). Included is a control valve incorporating backflow prevention, anti hammer, flow control and pressure limiting capabilities in full compliance with the relevant laws.

INSTALLATION REQUIREMENTS

1. 13 mm (½") Cold water line.
2. Min/Max pressure: 300 - 600 kPa.
3. Min/Max temperature 0° - 30°C (protect from freezing).
4. Suitable location for faucet.

Alternative fittings may be required if being connected to anything other than 15mm (½") copper pipe. No electrical or drainage requirements needed.

Product Code: SYS -ROCOMP

COMPACT REVERSE OSMOSIS TYPICAL INSTALLATION



Figure 1

- 1 Carbon Inline Filter**
Removes chlorine, taste & odours, cloudiness and colors.
6-12 months
- 2 RO Membrane**
Produces bottled quality drinking water up to 75 gallons per day.
3-4 years
- 3 Alkalisng Filter**
Adds calcium, magnesium and potassium. Raises the pH level of the water.
1-2 years

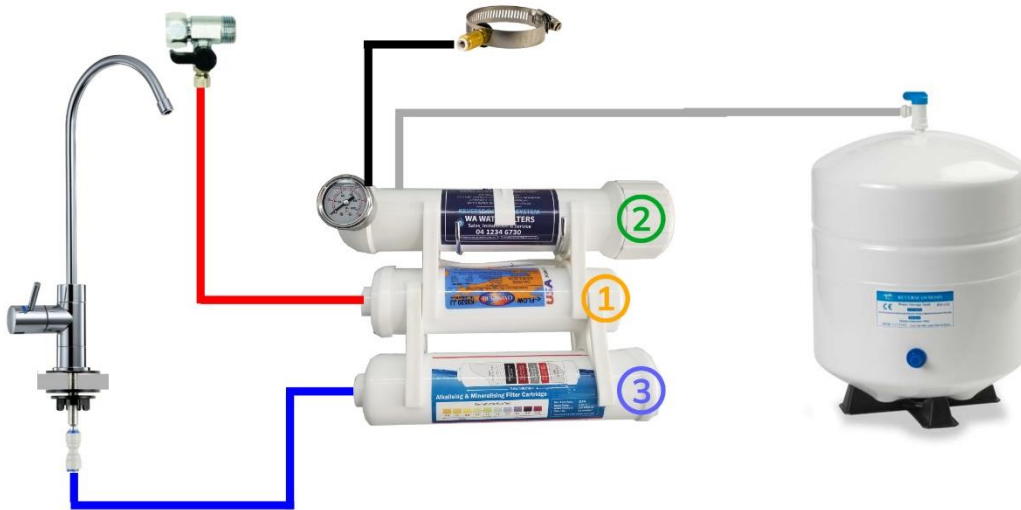

Product Code: SYS -ROCOMP

Figure 2

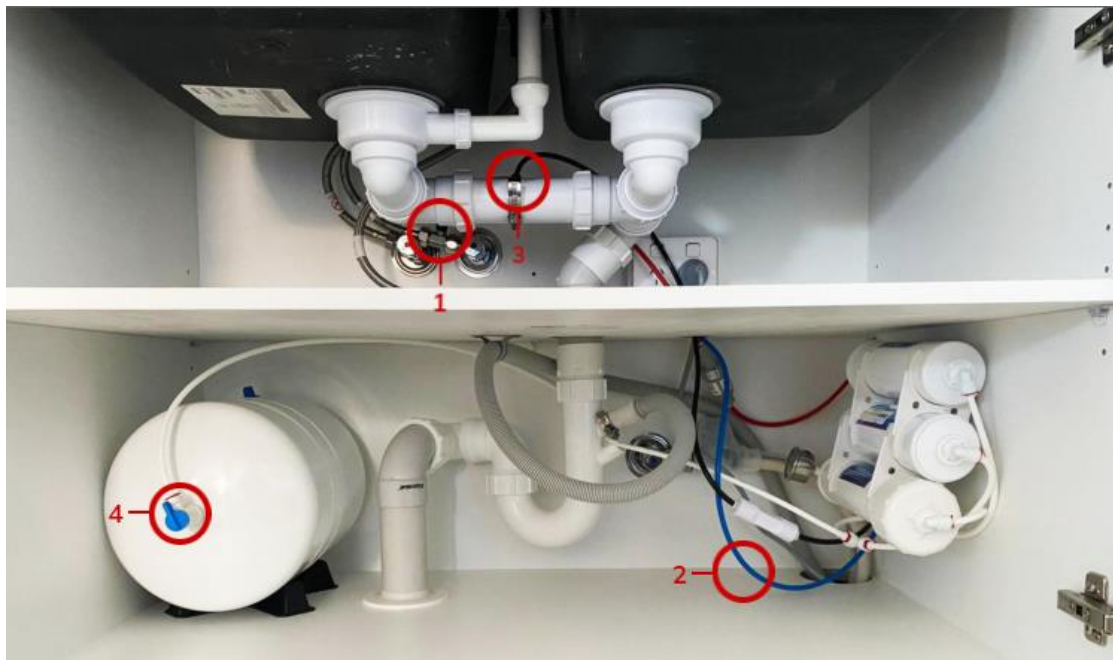

1. Mains Connector
2. Blue Tube Connects to Faucet
3. Black Tube Connects Drain Clamp
4. White Tube Connects to Tank Shut-Off Valve

INSTALLATION PROCEDURE

Important Note: Do not cut the BLACK tube when installing this system.

1. Find a convenient location: The System dimensions are 300W x 200 H x 100 D (mm), and the tank dimensions are 244 D x 366 H (mm). The tank can go laying down as well as the system.
2. Shut Off the water supply: Locate the connection between the kitchen tap & cold-water line (Usually a flex line). Shut off the incoming water and open the tap (cold water) to release the pressure.
3. Disconnect the cold water braided hose: If you do not know which one is the hot or cold, run the hot water for a while and feel the hoses.

FEEDING THE SYSTEM WITH HOT WATER, WILL DAMAGE THE SYSTEM

4. Install the mains adaptor: From the cold-water inlet, install the valve adaptor/mains connector in between. DO NOT apply thread tape to these connections as they are designed to use the washers only. (Fig 3)
5. Push the red tube all the way in to stop. **Connect ¼" RED inlet tube to mains connector.**
6. Check for leaks: With the black handle facing in line with the cold-water line (As pictured) the valve is in the off position. During this point, you can turn the water back on to check for leaks in the valve installation.

Figure 3



Product Code: SYS -ROCOMP

7. Select location on kitchen sink to install faucet. Make sure there is adequate access under the bench top for the hoses. The faucet supplied with the system requires a ½" (12 mm) hole. Use a centre punch to locate the position to drill.
8. Drill a pilot hole and gradually enlarge until you have the correct size hole.
9. To install faucet, insert the faucet into the hole in sink or bench. The faucet may be installed on any flat surface over 50mm (2") in diameter. (Remember: check the underside of the location for interference). Make a small indent using a centre punch to mark the desired drilling location. Drill a pilot hole with a metal drill. Enlarge the hole using a 1/2" metal drill bit.

Once the hole has been drilled install the faucet as per Figure 4. Be sure the faucet body, chrome plate, and the black rubber washer are placed above the sink. Install the black locating washer, the lock washer and nut underneath, then tighten firmly while aligning faucet in the desired direction. **Connect BLUE tube to faucet. (Fig 1)**

10. Reset LED indicator by following instructions on page 10.
11. Install the drain clamp by drilling a 4 mm hole in the waste pipe. Position the drain clamp above the trap. **Connect ¼" BLACK drain tube to drain clamp** and tighten compression nut. Do not allow drain hose to protrude more than 10 mm into drain, making sure the holes in the drain and the clamp are exactly aligned. This can be done by inserting a thin Phillips screwdriver through them whilst tightening the clamp. (Fig 4)
12. When connecting the red, black, blue and white tubes leave plenty of extra length so that the purifier can be repositioned during servicing without having to disconnect all the hoses.
13. **Connect WHITE tube to storage tank.** Screw ball valve to tank outlet and ensure valve is open. (Fig 5)
14. Once unit has been completely plumbed it will need to be actuated. To do this ensure isolation valve is off and faucet is open. Gradually open isolation valve to begin water production. The first sign will be water running to drain. This is normal and then finally product water will begin coming out faucet. This may take several minutes.
 - a. At this stage close faucet. This forces product water to fill up the storage tank. To check that water is still being produced, check water is running to drain. This should continue for several hours until tank is full. When tank is full, the pressure in the tank will overcome the inlet water pressure and the shut off valve will activate, shutting off the inlet water. To check this, check if water is running to drain. Once tank is full, no water should run to drain. To flush system, allow tank to fill, open faucet outlet until water stops, close faucet and allow tank to fill. Check all connections for leaks.
15. Reverse osmosis systems produce water slowly, almost drop to drop. If the tank is empty to begin with, it will take the tank 3 to 4 hours to fill. Reverse osmosis systems product water slowly. Initially filling the tank will take 3 - 4 hours. Fill and empty twice before drinking water from the system. This is essential in order to flush away any sterilising solution in the membrane.
16. Check all connections are tightened properly. Check for leaks.
17. To dispense drinking water from the faucet, push and hold the handle down or push up for continuous operation.
18. When the unit is in place and the water lines are installed, the unit should be run for 4 hours before the purified water is used, on initial start up. The unit cannot be stored for more than 2 weeks without use, or damage to the membrane may occur. Please enquire if this is the case. For a period of non-use greater than 2 days, flush for 10 minutes before use. For non-use periods of more than 2 weeks, the cartridges may need replacing.
19. The sediment and chemical removal filters should be replaced every 12 months. The membrane should be replaced when water quality deteriorates or every 36 - 48 months, depending on incoming water quality. Use only genuine AquaCo replacement cartridges and cartridges that are suitable for this appliance.

Figure 4



Figure 5



Product Code: SYS -ROCOMP

FAUCET INSTALLATION PROCEDURE

Figure 6 – Faucet Installation Diagram

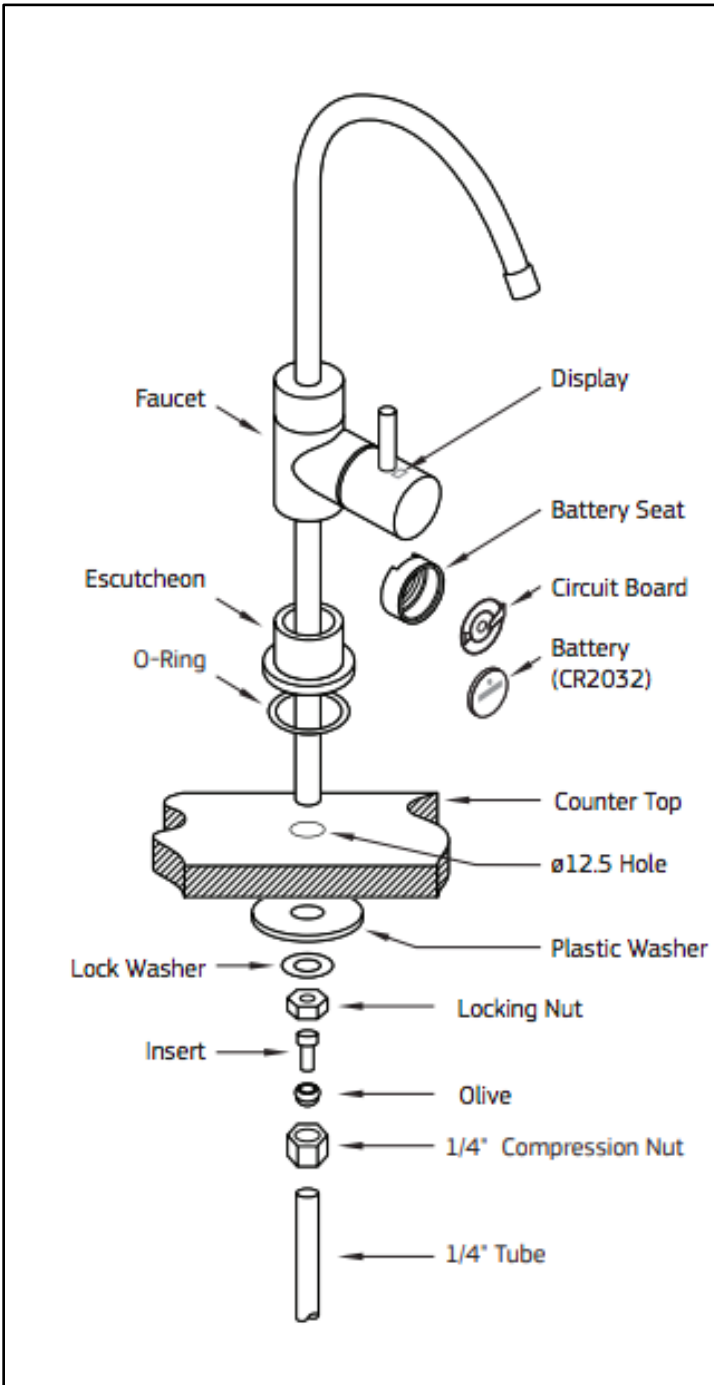

Important note: Battery must be replaced when changing cartridges.

FAUCET INSTALLATION PROCEDURE

1. Remove the black battery seat from the faucet lever handle (see Figure 7).
2. Install battery into the battery seat, positive side up, discard plastic insert.

Figure 7

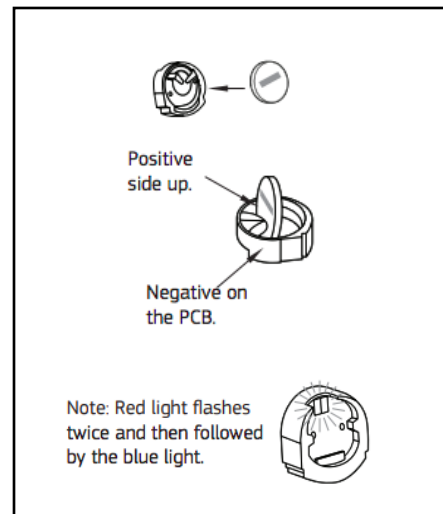

3. Reinstall battery seat assembly into the faucet lever, battery side facing outwards.

Figure 8

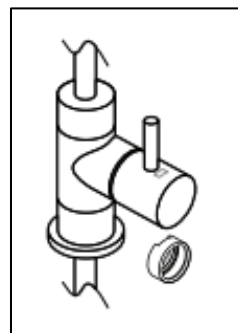
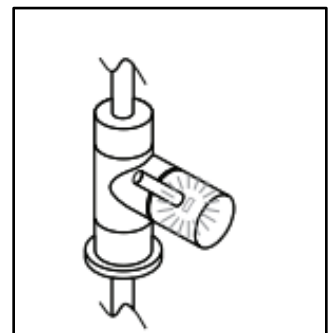

Figure 9



Product Code: SYS -ROCOMP

WARNING! THIS PRODUCT CONTAINS A BATTERY. ACCIDENTAL INGESTION MAY OCCUR AND CAN BE FATAL. PLEASE KEEP OUT OF REACH FROM INFANTS. IF YOU SUSPECT AN ACCIDENTAL INGESTION PLEASE CONTACT EMERGENCY SERVICES.

- 4. Blue light flashes during normal operation.
- 5. Red light flashes indicates your cartridges are due to be changed (usage has exceeded 3,000 minutes or 12 months). Please change the battery when changing the cartridges.

GUIDE TO USE PUSH-IN TUBE CONNECTORS

Figure 10

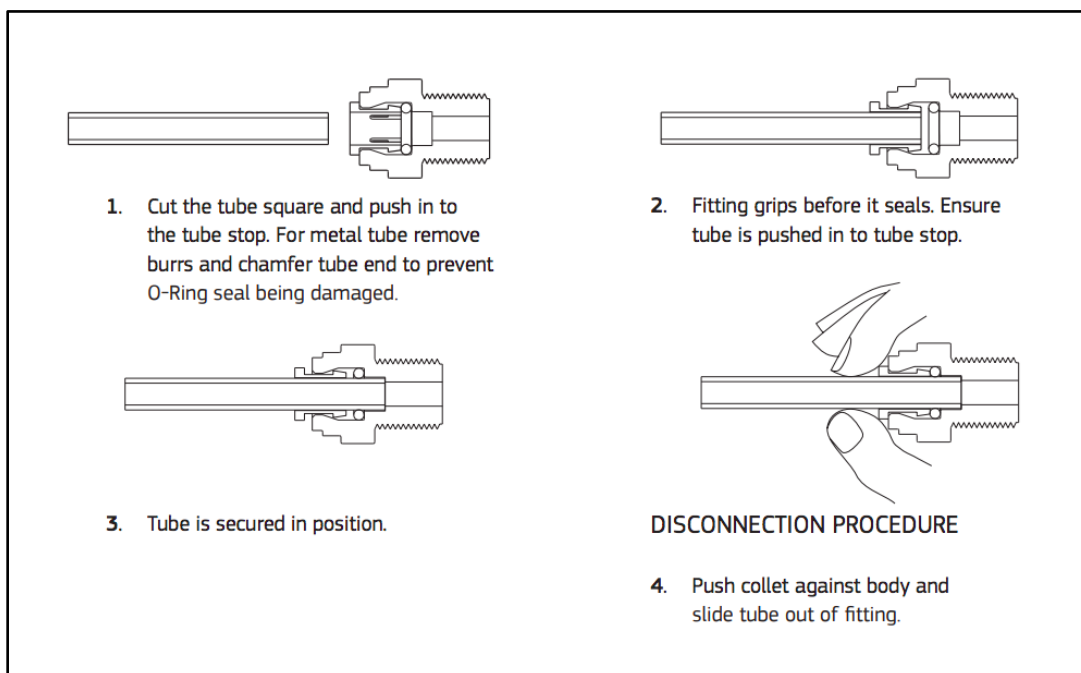

USE GUIDELINES

- Minimum operating pressure 300 kPa.
- Maximum operating pressure 600* kPa.
- Do not allow exposure to temperatures below 0°C.
- Maximum operating temperature 38°C.
- Nominal flow rate 4 Lpm.
- This system must be installed according to local plumbing codes on the cold water line.
- Replacement Cartridges: See Cartridge replacement section
- This system requires regular replacement of the filter cartridge to maintain proper operation. Varying chlorine, sediment, or organic substance levels may affect replacement frequency.
- Be sure to change the filter cartridge at least every 12 months which ever occurs first; or whenever you detect a change in taste, odour, or decrease in flow.
- When replacing cartridge, ensure you reset the LED reminder light by removing/replacing the battery from the rubber seat. Please refer to page 8 for a detailed diagram.

Product Code: SYS -ROCOMP

Caution: Do not use with water that is microbiologically unsafe or of unknown quality without adequate disinfection before or after the system.

CARTRIDGE REPLACEMENT GUIDE

You can obtain replacements from your local AquaCo dealer. To maintain performance, warranty and standards use genuine AquaCo replacements.

Figure 11

- 1 1st Stage: Carbon Inline Filter (Every year)
- 2 2nd Stage: RO Membrane (Every 3-4 years)
- 3 3rd Stage: Alkalising Filter (Every 2 years)



- 1st Stage: Carbon Inline Filter: IL-102040JJ-5
- 2nd Stage: 75 GPD Membrane: MEM-75GPDFLMTC
- 3rd Stage: Alkalising Filter: IL-1125BB-ALK

TO MAINTAIN THE HIGH QUALITY OF THE PURIFIED WATER THE CARTRIDGE(S) NEED CHANGING EVERY 6-18 MONTHS (THIS IS DEPENDENT ON WATER QUALITY AND USAGE). YOU CAN OBTAIN REPLACEMENT CARTRIDGES FROM YOUR LOCAL AQUACO STOCKIST. TO MAINTAIN PERFORMANCE AND WARRANTY USE GENUINE AQUACO REPLACEMENTS.

Product Code: SYS -ROCOMP

MEMBRANE SERVICE/MAINTENANCE

1. Disengage tubings from the membrane housing cap.
2. Disengage the housing and locate your membrane spanner and open the Membrane Housing. Membrane housing cap can be unscrewed by hand.
3. Remove the cap on the membrane housing and by using a pair of needle nose pliers remove the membrane with a twisting motion and discard the Membrane.

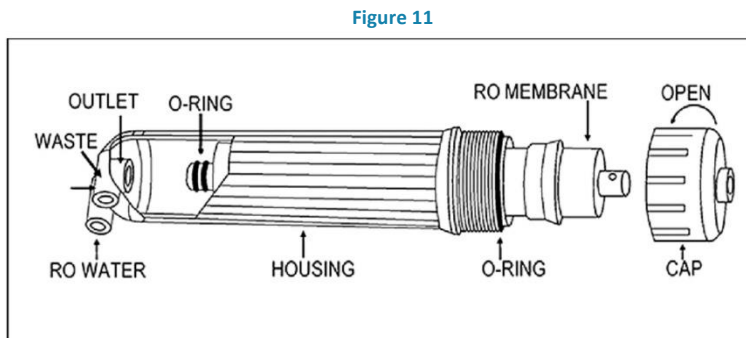

4. To connect the new filter membrane, remove membrane packaging, only remove the outer shrink-wrap packaging, DO NOT remove any other packaging from the membrane.
5. When installing the new membrane, please double check that the new membrane and the old membrane have the same specifications (part number).
6. Check the flow arrow in the new membrane and place the new membrane in the position as the previous membrane was.
7. Once the membrane is in the right position, INSERT THE NEW MEMBRANE
8. To make sure the membrane housing is fully sealed, you may use plumbers' silicone grease to lubricate the O-ring and the main seal. Screw in the membrane housing cap, and engage the membrane housing to the system. Then, connect the tubing. Push the tubes as far as they can go.
9. The process of flushing the membrane takes a bit more time. Turn on the water supply and the RO tank, allowing the system to refill it. Wait about two hours, then turn on the faucet letting the air out of the system and flushing the membrane. Repeat the flushing process at least one time, waiting at least 2 hours between each procedure.

ALKALISING INLINE SERVICE / MAINTENANCE

1. Locate your isolating valve connected to your cold-water supply. Turn isolating valve OFF.
2. Locate the tap on top of you tank. Turn the tap on top of your tank OFF. Go to your drinking faucet and open the tap to release the pressure.
3. Locate the filter cartridge to be replaced, and disconnect the hoses connected to that filter.

Note: Before disconnecting please check the flow arrow and specifications in the current filter to place the new filter in the correct position.

4. To disconnect the hose/tube, first remove the red clip. Use two fingers to push into the collet and at the same time pull out the tube. Repeat the same process to disconnect the hose at the other end of the filter cartridge. Then, remove and dispose the filter cartridge.
5. To connect the new filter cartridge, remove any protection that the filter may have at the ends.

Note: When installing the new filter, please double check that the new filter and the current filter have the same specifications (part number).

6. Check the flow arrow in the new filter and place the new filter in the position as the previous filter was. Once the filter is in the right position, push the tube as far as it can go and secure with a John Guest Clip.

Product Code: SYS -ROCOMP

- Repeat the step 6 to connect the other end of the new filter cartridge. Repeat the same process for any filter cartridge replacement.

REPLACEMENT PARTS AND COMPONENTS

	<p>Reverse Osmosis Membrane 75 TFC</p> <ul style="list-style-type: none"> • Fluoride & Nitrate removal. • 0.0005 micron rating for 98% removal of impurities.
---	--

Note: Chlorine (free chlorine) tolerance is 1ppm - high chlorine levels permanently damage the reverse osmosis membrane & is not covered under warranty. The maintenance of the pre-filtration system is always recommended to protect the performance of the reverse osmosis membrane.

<i>Version</i>	<i>Price</i>
<i>Reverse Osmosis Membrane</i>	<i>\$110</i>

*Prices are valid from the 01/11/2021 to 01/03/2022.
Water Filters Pty Ltd reserves the right to change pricing at any time without notice.

	<p>Inline Carbon Block Filter</p> <ul style="list-style-type: none"> • Protects the reverse osmosis membrane. • Removes chlorine, taste and odours.
---	--

<i>Version</i>	<i>Price</i>
<i>Inline Carbon Block Filter</i>	<i>\$59</i>

*Prices are valid from the 01/11/2021 to 01/03/2022.
Water Filters Pty Ltd reserves the right to change pricing at any time without notice.

	<p>Alkalisising/Mineralising Inline Filter</p> <ul style="list-style-type: none"> • Raises the pH level of the water >9 • Adds Calcium, Magnesium and Potassium. • Restores just the right proportion of healthy minerals and a natural alkaline balance.
---	--

<i>Version</i>	<i>Price</i>
<i>Alkalisising/Mineralising Inline Filter</i>	<i>\$95</i>

*Prices are valid from the 01/11/2021 to 01/03/2022.
Water Filters Pty Ltd reserves the right to change pricing at any time without notice.

Product Code: SYS -ROCOMP

PERFORMANCE DATA SHEET

PRODUCT CODE: IL-102020JJ-1

CARBON FILTER

Micron Rating	>98% @ 1 µm
Filter Dimensions	10" x 2"
Chlorine Reduction >95%	6,819 L @ 0.75 gpm
Initial_P	>5.0 psid @0.75 gpm
Carbon Type	Powdered Activated Carbon Block

NOTES: CHLORINE REDUCTION CAPACITY BASED ON LABORATORY TESTING CONDUCTED USING TEST PROTOCOL CONTAINED IN NSF STANDARD 42 AND 53.

PRODUCT CODE: MEM-75GPDFLMTC

REVERSE OSMOSIS MEMBRANE

Reverse Osmosis Element	Applied Pressure		Permeate Flow Rate		Typical Stabilized Salt Rejection (%)
	(psig)	(bar)	(GPD)	(L/h)	
TW30-1812-75	50	3.4	50	7.9	99%

1. PERMEATE FLOW AND SALT REJECTION BASED ON THE FOLLOWING TEST CONDITIONS: 500 PPM NAHCO3 , 77°F (25°C), PH 8.0, 15% RECOVERY AND THE SPECIFIED APPLIED PRESSURE.

2. MINIMUM SALT REJECTION IS 98.0%.

3. PERMEATE FLOWS FOR INDIVIDUAL ELEMENTS MAY VARY +25/-15%.

PRODUCT CODE: IL-1125BB-ALK

INLINE ALKALISING FILTER

Micron Rating	>98% @ 5 µm
Filter Dimensions	11" x 2.5"
Initial_P	>5.0 psid @0.75 gpm
Media Type	Volcanic Red Clay Ceramic Balls, Tourmaline Rock, Granular Phlogopite Rock, Granular Activated Carbon.

Product Code: SYS -ROCOMP

NOTES

AquaCo water care products are designed, manufactured and supported by Water Filters Pty Ltd the name you can trust for viable and proven water solutions. The complete range of AquaCo products are developed, refined, made to meet and exceed stringent specifications for the worldwide market.

Important: Sales of products are subject to our Terms and Conditions which are available upon request. All specifications, information and photos are a guide only and are subject to change without notice. Please ring to confirm details. Warning: For correct operation of this appliance it is essential to observe manufacturer's instructions.

WARRANTY

Any claim under this warranty must be made within 5 years of the date of purchase of the product. This product is warranted to be free of defect of material and workmanship for 5 years from date of purchase. 5 year warranty is 1 year parts and labour, plus 4 years parts only.

To make a claim under the warranty, take the product and proof of purchase to place where you purchased the product, and they will lodge a Warranty Request with AquaCo.

AquaCo will pay your reasonable, direct expenses of claiming under this warranty. You may submit details and proof of your expense claim to place of purchase for consideration.

The warranty only applies if the product was used and/or installed in accordance with the user guide and/ or installation instructions. This warranty is given in lieu of all other express or implied warranties and manufacturer shall in no circumstance be held liable for damages consequential or otherwise or delays caused or faulty manufacturing except as excluded by law.

Applicable to all above, is that the Warranties need to be approved by AquaCo to ensure product was not incorrectly used, installed or claimed. False and incorrect claims will be pursued at AquaCo's discretion, including chargeable inspection and labour costs incurred.

All installation and service work should be completed by qualified tradespeople. Faulty operation due to unqualified persons will result in voided warranty coverage.

Use PTFE thread seal tape on all connections. Use of liquid pipe sealant/dope will void warranty.

Warranty/Australia

This warranty is given by Water Filters Pty Ltd, ABN 68618671677, telephone no. 08 6156 0220 and email at sales@waterfilter.com.au.

This warranty is provided in addition to other rights and remedies you have under law: Our goods come with guarantees which cannot be excluded under the Australian Consumer Law. You are entitled to replacement or refund for a major failure and to compensation for other reasonably foreseeable loss or damage. You are also entitled to have the goods repaired or replaced if the goods fail to be of acceptable quality and the failure does not amount to a major failure.