

Product Code: RO-COM20

WARNING: For correct operation & installation, it is essential to observe these instructions.

AQUACO COMMERCIAL REVERSE OSMOSIS WATER FILTRATION SYSTEM



Product Code: RO-COM20

CONTENTS

AquaCo Commercial Reverse Osmosis Water Filtration System	1
Installation and Operation Manual	3
AquaCo Customer Service	3
Minimum and Maximum Operating Conditions	3
Operation	3
Installation	4
Installation requirements	4
System Dimensions	4
Typical Installation	5
Components	5
Maintenance for periods of time without operation	6
Cartridge Installation/Maintenance	6
Guide to use Push-In Tube Connectors	6
Use Guidelines	7
Cartridge Replacement Guide	8
Performance Data Sheet	9
Notes	10
Warranty	10
Price	12
Default	12
Severence	12
Warranty/Australia	12

Product Code: RO-COM20

INSTALLATION AND OPERATION MANUAL

AQUACO CUSTOMER SERVICE

Thank you for purchasing an AquaCo reverse osmosis water filter system. Your system is a proven performer manufactured from only quality materials and components and will give years of 'spring fresh' water free of impurities if maintained properly.

Caution: Do not use with water that is microbiologically unsafe or with water of unknown quality without adequate disinfection before or after the system.

The system is designed for metropolitan supply water but can be used in other situations. For other types of water supply please contact your local AquaCo stockist or call our AquaCo Customer Service Helpline.

The AquaCo filter systems cartridges need replacing regularly to maintain optimum performance. This is a simple procedure when following instructions. For cartridge replacements contact your nearest AquaCo stockist.

Customer Service Helpline 08 6156 0220 (Australia).

MINIMUM AND MAXIMUM OPERATING CONDITIONS

Condition	Minimum	Maximum
Inlet Pressure	40 PSI	80 PSI
Inlet Temperature	0°C	30°C
Inlet TDS	50 mg/L	2,000 mg/L
Inlet Hardness	0 mg/L (0 grain)	171 mg/L (10 grain)

Note: Required input water pressure 40 to 80 psi inline pressure. It can produce up to 1800 Litres a day, depending on the incoming water pressure, required pressure between 40 psi to 80 psi.

OPERATION

The AquaCo reverse osmosis systems are designed to run economically for many years, dependent on the initial installation and periodical maintenance.

Flush systems for 10 minutes after any period of non-use more than 2 days. For a period of non-use of 2 weeks or more, it may be necessary to replace cartridges.

This product must be installed in accordance with local plumbing regulations by a licensed plumber.

Installation Note: A water filter system/tap, like any product, has a limited life and may eventually fail. Also, sometimes failure happens early due to unforeseen circumstances. To avoid possible property damage, this product should be regularly examined for leakage and/or deterioration and replaced when necessary. A drain pan, plumbed to an appropriate drain or outfitted with a leak detector, should be used in those applications where any leakage could cause property damage, and/or the water supply should be turned off if no one is home/present.

Product Code: RO-COM20

INSTALLATION MUST BE COMPLETED BY A LICENCED PLUMBER. FAULTY OPERATION DUE TO UNQUALIFIED PERSONS WILL RESULT IN VOIDED WARRANTY COVERAGE.

Note: Chlorine (free chlorine) tolerance is 1ppm - high chlorine levels permanently damage the reverse osmosis membrane & is not covered under warranty. The maintenance of the pre-filtration system is always recommended to protect the performance of the reverse osmosis membrane.

INSTALLATION

This system comes complete with an installation kit enabling it to be connected to 1" or ¾" (cold supply only - hot water should be filtered prior to heating). Included is a HEX Nipple 1" to ¾" to fit ¾" adaptors if required.

INSTALLATION REQUIREMENTS

1. Connects to 1" or ¾" Cold water line.
2. Min/Max pressure: 40 - 80 PSI.
3. Min/Max temperature 0° - 30°C (protect from freezing).
4. Suitable location for faucet, tank or machine.

Alternative fittings may be required if being connected to anything other than (1" or ¾" copper pipe).

SYSTEM DIMENSIONS

System Dimensions: 460 W x 800 H x 240 D (mm)

Optional Tank Dimensions:

60L Capacity Reverse Osmosis (RO-1070) Tank Dimensions: 389 D x 626 H (mm)

80L Capacity Reverse Osmosis (RO-2000) Tank Dimensions: 389 D x 790 H (mm)

150L Capacity Reverse Osmosis (RO-150) Tank Dimensions: 430 D x 1065 H (mm)

Product Code: RO-COM20

TYPICAL INSTALLATION



Note: Tubing is colour coded for ease of installation.

BLACK – WATER WASTE: 1/4" Black Tube Connects Drain Clamp.

WHITE – FEEDS TANK: 3/8" White Tube Connects to Tank Shut-Off Valve.

BLUE – 3/8" Blue Tube Connects to Faucet or Machine.

COMPONENTS

- **3 Stage Filtration System**
 - a. Housing Sump with 1st Stage Filter (Sediment Pre-Filter)
 - b. Housing Sump with 2nd Stage Filter (Carbon Block)
 - c. Membrane Housing with 3rd Stage Filter (RO Membrane)
- 1/4" 1600cc Flow Restrictor
- 1/4" Quick Connect Drain Clamp
- 3/8" Check Valve
- 3/8" Auto Shut-Off Valve
- 3/8" White Tubing
- 1/4" Black Tubing
- 3/8" Blue Tubing
- 3/8" Tee with 3/8" Push-In Tube Connector

Product Code: RO-COM20

MAINTENANCE FOR PERIODS OF TIME WITHOUT OPERATION

The unit cannot be stored for more than 2 weeks without use, or damage to the membrane may occur. Please enquire if this is the case. For a period of non-use greater than 2 days, flush for 10 minutes before use. For non-use periods of more than 2 weeks, the cartridges may need replacing.

The sediment and chemical removal filters should be replaced every 6-12 months. The membrane should be replaced when water quality deteriorates or every 6 - 12 months, depending on incoming water quality. Use only genuine AquaCo replacement cartridges and cartridges that are suitable for this appliance.

CARTRIDGE INSTALLATION/MAINTENANCE

GUIDE TO USE PUSH-IN TUBE CONNECTORS

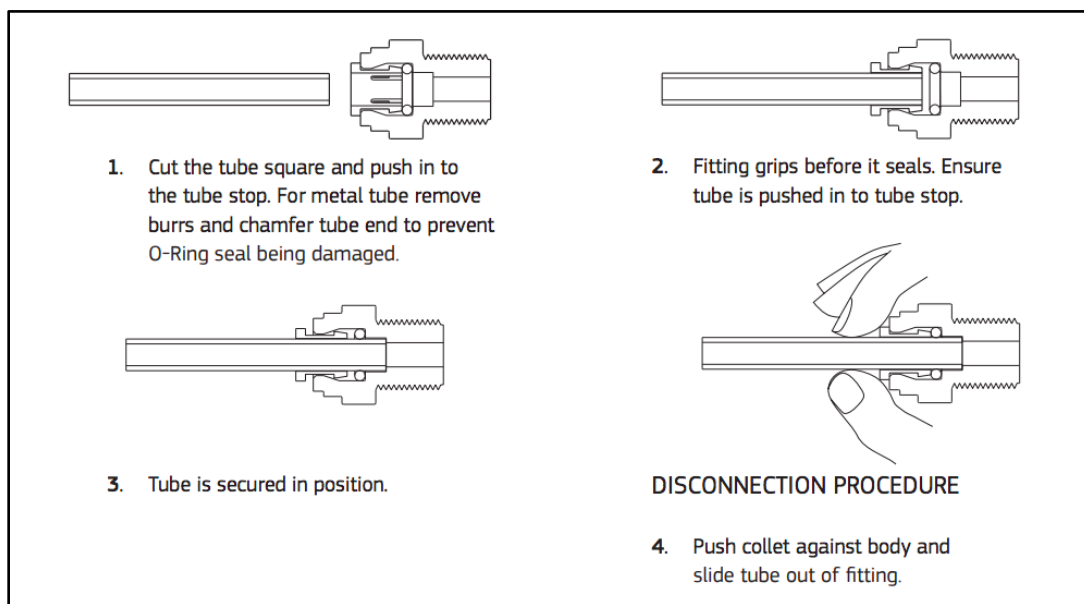

Product Code: RO-COM20

USE GUIDELINES

- Minimum operating pressure 270 kPa (40 psi)
- Maximum operating pressure 550 kPa (80 psi)
- Do not allow exposure to temperatures below 0°C.
- Maximum operating temperature 38°C.
- This system must be installed according to local plumbing codes on the cold-water line.
- Replacement Cartridges: See Cartridge replacement section (See Page 8).
- This system requires regular replacement of the filter cartridge to maintain proper operation. Varying chlorine, sediment, or organic substance levels may affect replacement frequency.
- Be sure to change the filter cartridge at least every 12 months; or whenever you detect a change in taste, odour, or decrease in flow.

Caution: Do not use with water that is microbiologically unsafe or of unknown quality without adequate disinfection before or after the system.

Product Code: RO-COM20

CARTRIDGE REPLACEMENT GUIDE

You can obtain replacements from your local AquaCo dealer. To maintain performance, warranty and standards use genuine AquaCo replacement filters.



AquaCo Commercial Reverse Osmosis Replacement Filters

- 1st Stage: Sediment Filter: PP-2045-5-WAWF
- 2nd Stage: Carbon Filter: CB-2045-5-WAWF
- 3rd Stage: 500GPD RO Membrane: MEM-500GPD

TO MAINTAIN THE HIGH QUALITY OF THE PURIFIED WATER THE CARTRIDGE(S) NEED CHANGING EVERY 6-12 MONTHS (THIS IS DEPENDENT ON WATER QUALITY AND USAGE). YOU CAN OBTAIN REPLACEMENT CARTRIDGES FROM YOUR LOCAL AQUACO STOCKIST. TO MAINTAIN PERFORMANCE AND WARRANTY USE GENUINE AQUACO REPLACEMENTS.

Product Code: RO-COM20

PERFORMANCE DATA SHEET

PRODUCT CODE: PP-2045-5-WAWF

SEDIMENT FILTER

Micron Rating	Triple Gradient: 20 µm (outer), 10 µm (middle), 5 µm (inner)
Filter Dimensions	20" x 4.5"
Media Type	100% Polypropylene

NOTES: THIS CARTRIDGE IS TESTED AND CERTIFIED BY NSF INTERNATIONAL UNDER NSF/ANSI STANDARD 42 FOR MATERIAL REQUIREMENTS ONLY.

PRODUCT CODE: CB-2045-5-WAWF

CARBON FILTER

Micron Rating	>98% @ 5
Filter Dimensions	20" x 4.5"
Chlorine Reduction >95%	100,000 gallons @ 15 gpm
Initial_P	>5.0 psid @15 gpm
Carbon Type	Activated Carbon

NOTES: CHLORINE REDUCTION CAPACITY BASED ON LABORATORY TESTING CONDUCTED USING TEST PROTOCOL CONTAINED IN NSF STANDARD 42 .

PRODUCT CODE: MEM-500GPD

REVERSE OSMOSIS MEMBRANE

Reverse Osmosis Element	Applied Pressure		Permeate Flow Rate		Typical Stabilized Salt Rejection (%)
	(psig)	(bar)	(GPD)	(L/h)	
TW-3012-500	70	4.8	500	79	96%

1. PERMEATE FLOW AND SALT REJECTION BASED ON THE FOLLOWING TEST CONDITIONS: 250 PPM NA₂CO₃, 77°F (25°C), PH 8.0, 40% RECOVERY AND THE SPECIFIED APPLIED PRESSURE.

2. MINIMUM SALT REJECTION IS 96.0%.

3. PERMEATE FLOWS FOR INDIVIDUAL ELEMENTS MAY VARY +25/-15%.

Product Code: RO-COM20

NOTES

AquaCo water care products are designed, manufactured and supported by Water Filters Pty Ltd the name you can trust for viable and proven water solutions. The complete range of AquaCo products are developed, refined, made to meet and exceed stringent specifications for the worldwide market.

Important: Sales of products are subject to our Terms and Conditions which are available upon request. All specifications, information and photos are a guide only and are subject to change without notice. Please ring to confirm details. Warning: For correct operation of this appliance, it is essential to observe manufacturer's instructions.

WARRANTY

Any contract of sale, order, or quotation made or accepted by or on behalf of Water Filters Pty Ltd (trading as AquaCo Filters) is subject to these terms and conditions of sale.

- AquaCo Filters warrants AquaCo Filtration Systems to the original purchaser for a period of 5 years for Retail customers, and 2 years for Wholesale and Trade customers from the date of sale established by the date of the original invoice issued by an authorized distributor.
- AquaCo Filters warrants each new Product to be free from defects in the product for a period of 2 year from the date of retail sale established by the date of the original invoice issued by AquaCo Filters.
- AquaCo Filters reserves the right in instalment sales to grant credit for the value of any Product found to be defective under this Warranty.
- AquaCo Filters will not cover any labour charge incurred by the Buyer for the replacement or repair of any Product.
- The Buyer is responsible for freight and local labour charges for Products the subject of this Warranty.
- This Warranty applies only to the original purchaser of the Product.
- AquaCo Filters' obligation under this Warranty is limited to AquaCo Filters' own option, to either repair or replace the Product, once AquaCo Filters has deemed that the Product is defective or AquaCo Filters may, at its own discretion, refund to the Buyer the purchase price paid for the defective goods.
- This Warranty does not cover any Product that is relocated from the site of its original installation.
- All replaced or exchanged parts taken out under this warranty become the property of AquaCo Filters.
- This Warranty is subject to the Product being properly installed, maintained, being used for its intended purpose and operated strictly in accordance with AquaCo Filters' recommendations and installation guide.
- This Warranty does not extend to a Product that has been modified in any way unless with AquaCo Filters' express consent.
- This Warranty does not cover the normal wear and tear of the Product, or damage caused by misuse, abuse or vandalism. The Warranty does not cover any malfunction or failure resulting from neglect, use of unauthorised parts and accessories or use with higher water pressure than indicated on the Product.
- The Warranty does not extend to damage caused by rain, fire, earthquake or other natural causes or acts of nature.
- It is expressly agreed that this shall be the sole and exclusive remedy of the Buyer stated herein, and under no circumstances shall AquaCo Filters be liable for any costs, loss, expense, damages, special damages, incidental damages or consequential damages arising directly or indirectly from the design, manufacture, sale, use or repair of the Product whether based upon warranty, contract, tort or strict liability.
- All Conditions and Warranties implied by law or statute are hereby expressly negated so far as they lawfully can be.

ACCEPTANCE AND CLAIMS

- Acceptance of the Products shall be deemed for all purposes to have taken place at the expiration from the date of each delivery.
- Any damage caused during or as a result of transit will not be the responsibility of AquaCo Filters.

Product Code: RO-COM20

- Any faulty systems must be returned with the Pressure Limiting Valve.
- In the event of a Warranty Claim, the Product must be forwarded at the Buyer's own risk and expense to AquaCo Filters, together with proof of purchase.
- This limited Warranty is void if the Product under Warranty is presented without the said original invoice.
- AquaCo Filters may request that a Statement accompany the Original Invoice, signed by the Buyer, setting out the following terms:
 - The name and address of the Buyer.
 - The date and by whom the Product was purchased.
 - The date and by whom the Product was installed.
 - The location where the Product was installed.
 - The date and time the Product first appeared to malfunction.
 - The nature of the problem with the Product.
 - The date and time of any and all loss event/s.
 - The date and time AquaCo Filters were first notified of the Product malfunction.
- A failure by the Buyer to submit the said Statement within 28 days, after such request is made by AquaCo Filters, will automatically void the Warranty.
- A failure to answer truthfully or to answer in a way that is misleading, entitles AquaCo Filters to void the Warranty and to notify the police in the event of suspected fraudulent conduct.

RISK

- The risk in the Product will pass to the Buyer immediately upon the Product leaving AquaCo Filters' premises for delivery to the place designated by the Buyer.

RETENTION OF TITLE

- AquaCo Filters will retain title to (but not risk in) a Product delivered to the Buyer until AquaCo Filters has received payment in full for such Product from the Buyer.
- The Buyer will store the goods in such a way as to enable them to be separately identified and will keep them insured at its own expense with AquaCo Filters' interest noted on any such insurance cover.
- If the Buyer fails to make any payment when due or becomes bankrupt or becomes insolvent, or has a judgement entered against it in any Court or enters into any scheme of arrangement, composition, or assignment or is in receivership or voluntary administration or liquidation, the Buyer grants AquaCo Filters the license to enter any of the Buyer's premises where the Product is stored, and without notice, to re -take possession of and remove, at the Buyer's cost and expense, the Product in respect of which title has not passed to the Buyer.

RIGHTS FORFEITED

The Buyer forfeits any right or claim against AquaCo Filters warrantee if:

1. The System is operated with a water temperature higher than 38° Celsius.
2. The System is not serviced every 12 months. i.e., replacement of filters, PLV check and assessment of general condition of the system. If the drinking water quality is poor, the System should be serviced before 12 months.
3. The System damage results from water hammer, freezing, neglect or is not installed by a licensed plumber in accordance with the AS3500 plumbing code and installation plan.
4. The System is subject to water pressure that exceeds the maximum recommended pressure.
5. The System is not installed with an Australian Standards approved Pressure Limiting and Dual Check Valve.
6. The System has been found to be tampered with or if the goods have not been operated or maintained strictly in accordance with AquaCo Filters' recommendations.
7. The System is not turned off when the residents are away for over 24 hours.

Product Code: RO-COM20

PRICE

- The price charged shall be AquaCo Filters' price ruling at the date of delivery unless otherwise agree in writing. Any price indications or price lists are subject to alterations to AquaCo Filters' price ruling at the date service or goods are supplied.
- Prices are as per AquaCo Filters' wholesale unless otherwise agreed in writing.
- The Buyer is responsible to effect and meet the costs of any insurance cover that is deemed necessary.
- Clerical errors in computations, typing or otherwise of "catalogue, quotation, acceptance, invoice, delivery docket or other document" shall be subject to correction.
- Any goods returned through no fault of AquaCo Filters will be subject to a 15% restocking fee.

DEFAULT

On the happening of any one or more of the following events, namely:

- The Buyer fails to make payment to AquaCo Filters on the due date;
- An administrator or liquidator is appointed over any or all of the assets of the Buyer or a scheme of arrangements is proposed to approve with respect to the Buyer;
- In the case of the Buyer being a natural person, the Buyer commits an act of bankruptcy; then AquaCo Filters may at its option exercise all or any of the following rights (notwithstanding any prior failure to exercise such rights):
 - a. demand payment of the whole of the monies owing from the Buyer to AquaCo Filters and the Buyer agrees to pay the same immediately.
 - B. the Buyer shall pay to AquaCo Filters interest on such amount outstanding at the rate of 2% per month and any costs with respect to solicitors, legal advisors, mercantile agents and other agents acting on behalf of AquaCo Filters in respect of any enforcement hereof or recovery or attempted recovery of monies owing by the Buyer to AquaCo Filters.

SEVERENCE

If any of these terms or conditions become for any reason wholly or partly invalid, that term or condition shall to the extent of the invalidity be severed without prejudice to the to the continuing force and validity of the remaining terms and conditions.

JURISDICTION

AquaCo Filters and the buyer agree that this agreement and its provisions shall be construed in accordance with the laws of the State of Western Australia and be resolved by a Western Australian Court.

WARRANTY/AUSTRALIA

This warranty is given by Water Filters Pty Ltd, ABN 68618671677, telephone no. 08 6156 0220 and email at sales@waterfilter.com.au.

This warranty is provided in addition to other rights and remedies you have under law: Our goods come with guarantees which cannot be excluded under the Australian Consumer Law. You are entitled to replacement or refund for a major failure and to compensation for other reasonably foreseeable loss or damage. You are also entitled to have the goods repaired or replaced if the goods fail to be of acceptable quality and the failure does not amount to a major failure.